



ARPAC L26

Automatic L-Sealers



The ARPAC L26 automatic L-bar Sealers offer you the latest in shrink packaging technology, featuring a rugged design that provides fast user friendly operation at speeds up to 40 packages per minute. The L26 is perfect for contract packaging and other environments where quick changeovers are a necessity.

Standard Features

- Speeds up to 40 products per minute
- Intermittent motion wrapping
- Film cradles for simple film loading
- Guillotine style seal head
- Unique film trim takeaway
- Stroke limiting adjustable seal head
- Quick product changeovers
- Industry standard Allen Bradley electrical components
- Film type: center folded Polyolefin, PVC or polyethylene
- Digital controls for conveyor speeds, timing, and temperature settings for fast accurate setup when changing product size and film
- ARPAC's operator interface features a color touch screen with message display and self diagnostics
- NEMA 12 electrical cabinet and controls

Optional Features

- Pneumatic hole punch
- Infeed product guides
- Lower film cradle
- Printed film registration capability
- Stainless steel construction

Applications

ARPAC L-Series will wrap a variety of products, including (but not limited to):

- Magazines
- Pads of paper
- Light bulbs
- Video tapes
- CDROMs
- Pharmaceutical products

Your **ultimate** source for your packaging materials & equipment

HSA PACKAGING SYSTEMS

21500 Blythe Street, Canoga Park, CA 91304

Tel: (818) 712-0100; Toll Free: (800) 326 5937; Fax: (818) 712-0470

Email: sales@hsapackaging.com; Web: www.hsapackaging.com



ARPAC L26

Automatic L-Sealers



SPECIFICATIONS

	Package Specifications			Machine Specifications		
Package Sizes	W	L	H	W	L	H
Min Package	½"	4	¼"	46	78	60
Max Package	19"	26 ½"	8"			
Max Film Width	30" Centerfolded					
Max Film Diameter	12"					
Seal Bar Dimensions	21 ½" W			27 ½" L		
Max Wrapper Speed	40 PPM					
* - Not all values can be combined. Contact factory with samples for evaluation and quotation						
Loading Elevation	32.5-36.5 inches (83-93 cm)					
Discharge Height	32.5-36.5 inches (83-93 cm)					
Shipping Weight (std model)	1,600 pounds (1138 kg)					
Electrical Power	220VAC,	60Hz	1-ph	20A		
Compressed Air	80 PSI, up to 5 SCFM					

Your **ultimate** source for your packaging materials & equipment

HSA PACKAGING SYSTEMS

21500 Blythe Street, Canoga Park, CA 91304

Tel: (818) 712-0100; Toll Free: (800) 326 5937; Fax: (818) 712-0470

Email: sales@hsapackaging.com; Web: www.hsapackaging.com



ARPAC L26 Automatic L-Sealers

Machine Schematics

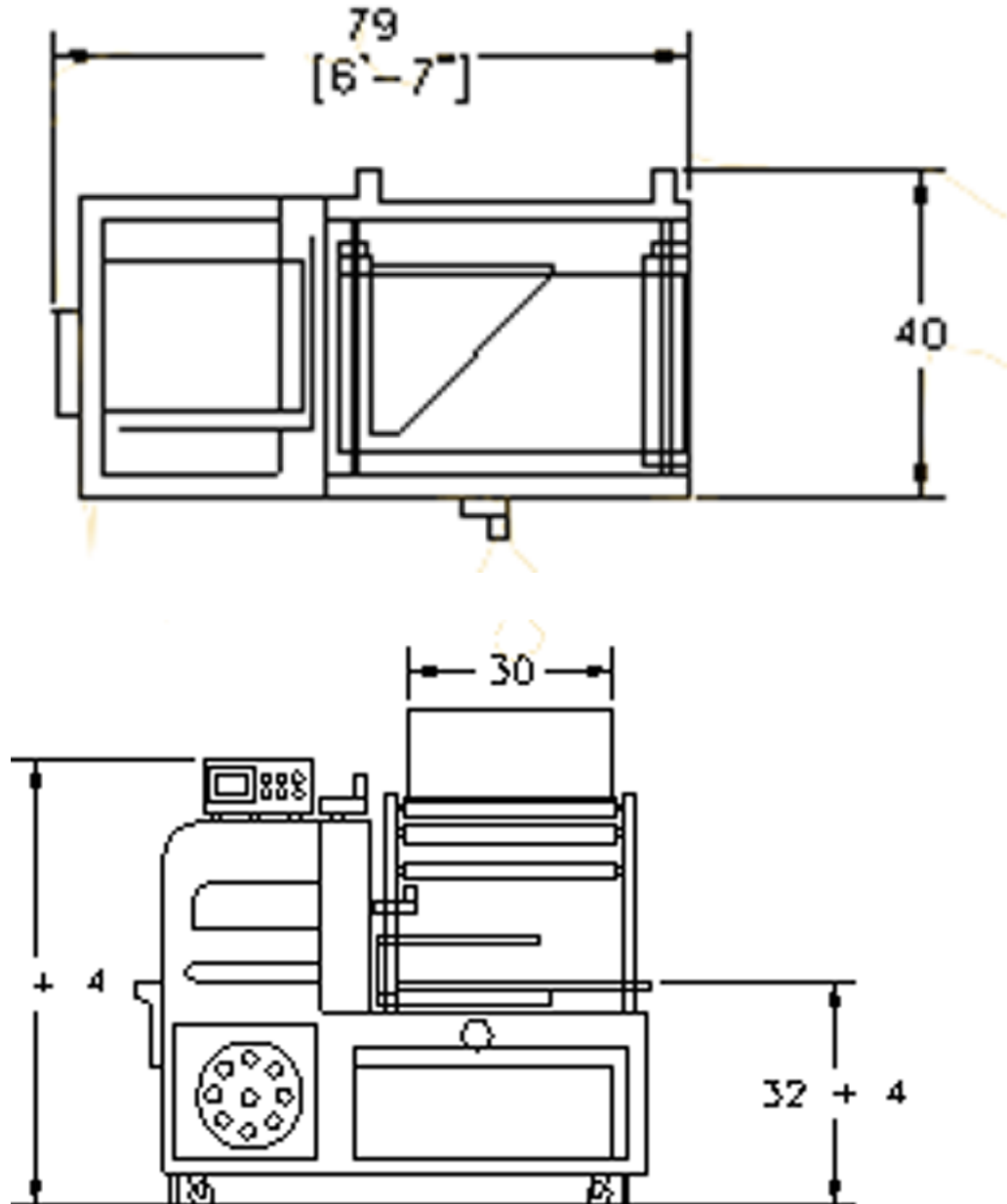

Mechanical Typical Dimensions

Your **ultimate** source for your packaging materials & equipment

HSA PACKAGING SYSTEMS

21500 Blythe Street, Canoga Park, CA 91304

Tel: (818) 712-0100; Toll Free: (800) 326 5937; Fax: (818) 712-0470

Email: sales@hsapackaging.com; Web: www.hsapackaging.com