



A Division of Manakz Corporation

Strapping Machines Model P725 Semi-Automatic

- ◆ Easy PC board replacement. All operating functions such as strap feed, strap tension and heater bar temperature are controlled by a printed circuit board. In the event of a circuit failure, replacement is a quick and easy operation.
- ◆ Automatic motor shut-off if not used within 60 seconds. Offers instant resumption of operation when needed.
- ◆ Heater blade reaches operating temperature in just 5 seconds and maintains an optimum operational level while in use.
- ◆ High speed transmission system with electromagnetic clutch, allows for excellent performance of only 1.5 per second cycle, providing less wearing components, for better reliability and longevity.
- ◆ Capacitor start motor reduces the "start" current of the motor to prevent overheating.
- ◆ Unique heater element avoids electric leakage, short circuits and lengthens the life of the heater blade.
- ◆ Adjustable package guides ensure positioning accuracy of package over sealing head.
- ◆ Accepts strap sizes 1/4", 3/8", or 1/2" with no additional parts required.
- ◆ Through the use of an outside adjustable knob the strap tension can be adjusted up to 132 pounds without the need to open the top cover.
- ◆ Model P625E and P725E have electrically controlled tension



- ◆ Low voltage control circuit for operator safety.
- ◆ Casters for portability.
- ◆ 110 volt allows for use anywhere in the facility.
- ◆ Feed button control for pre-set strap lengths.
- ◆ Simple touch of the reset button automatically returns machine to its starting position.
- ◆ Reversible cutter blade for greater cutting life.
- ◆ All electrical power cuts off when doors or table top is open.
- ◆ Hinged, interlocked cover provides safe, easy access to strapping mechanism for maintenance, cleaning or tension adjustment

Some photos may show accessories not part of basic machine. Specifications & Designs may change without notice

Your **ultimate** source for packaging materials & equipment

HSA PACKAGING SYSTEMS

21500 Blythe Street, Canoga Park, CA 91304
Tel: (818) 712-0100; **Toll Free: (800) 326 5937**; Fax: (818) 712-0470
Email: sales@hsapackaging.com; Web: www.hsapackaging.com



A Division of Manakz Corporation

Strapping Machines Model P725 Semi-Automatic

SPECIFICATIONS

Strapping speed	1.5 sec/strap
Minimum Package Size	1.25" High x 2.5" Wide
Maximum Package Size	No Limit
Maximum Package Weight	132 Lbs.
Strap Width	1/4", 3/8", and 1/2"
Tensioning Range	10 to 132 Lbs.
Power Supply	110V, Single Phase
Machine Weight	220 Lbs.
Shipping Weight	244 Lbs.
Machine Dimensions	35.2"(L) 22.3"(W) 28.7"(H)

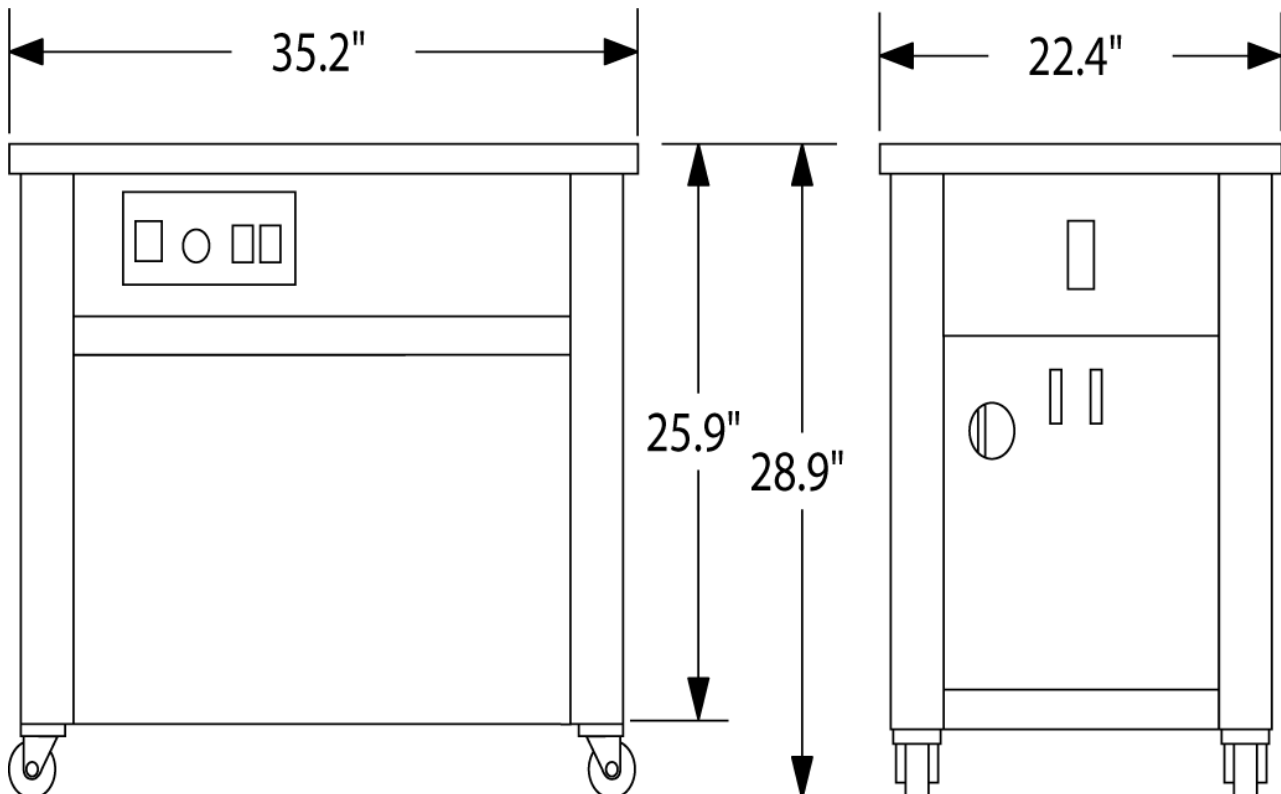

Some photos may show accessories not part of basic machine. Specifications & Designs may change without notice

Your **ultimate** source for packaging materials & equipment

HSA PACKAGING SYSTEMS

21500 Blythe Street, Canoga Park, CA 91304
Tel: (818) 712-0100; **Toll Free: (800) 326 5937**; Fax: (818) 712-0470
Email: sales@hsapackaging.com; Web: www.hsapackaging.com